

Feeder Centrifugal Conveyor « FCC »



FCC-500-O24681-CW

The advantages of our product:

- Centrifugal module on mobile carts
- Centrifuge belongs to the more efficient feeding and sorting technology.
- Outlet of the centrifuge combined with motorized conveyor belt.
- Speed of the two turntables and conveyor belt adjustable with motor controllers.
- Conveying direction: clockwise (CW) or counterclockwise (CCW)

Key data:

- Working height conveyor belt: from 950 to 1'250mm
- Outer diameter: 300 / 500 / 900mm
- Achievable conveying capacity: from 200 to 1'000pcs/min.
- Electrical connection: 230V/50Hz
- Special versions 110V/60Hz on request

Technical specifications:

Features for standard design	Typ	FCC					
	Unit	120	140	170			
Weight	Kg	80.0	100.0	150.0			
Filling volume in the centrifuge	L (dm3)	1.5	2.5	5.0			
Current absorbed	A	20	20	20			
Number of motors (without belt)	Pcs	2	2	2			
Number of motors (with belt)	Pcs	3	3	3			
Noise emission	dB	< 75					
Electr. version (CH+EU)	V / HZ	230V / 50Hz					
Electr. version (US)*	V / HZ	110V / 60Hz					
Temperature ambient	°C	+10 bis +45					
Protection class	IP	40					

Options and accessories:

- Hopper system with level monitoring
- Vibration drive controller for hopper
- Adjustable height with additional guide systems and hand crank, add. height up to +300mm.
- Integrated cover with noise protection hood
- Inspection unit to measure and sort out parts (available on request)
- Complete feeding module with separation and/or handling system (available on request)

Article no. ID:

FCC	-	500	-	O(xxxxx)	CW / CCW
					<p>CW: Clockwise CCW: Counter-Clockwise</p> <p>5-digit no. depending on version: Standard 1xxxx = frame on adjustable feet Option 2xxxx = frame on wheels as mobile trolley Option x3xxx = without vibratory hopper system Option x4xxx = with vibratory hopper system Option xx5xx = without adjustable height/hand crank Option xx6xx = with adjustable height/hand crank Option xxx7x = motor controller with potentiometer Option xxx8x = motor controller with digital keypad Option xxxx1 = without noise protection cover Option xxxx2 = with noise protection hood</p> <p>Size: Outer diameter (mm)</p> <p>FCC: Feeder Centrifugal Conveyor</p>

Dimensions:

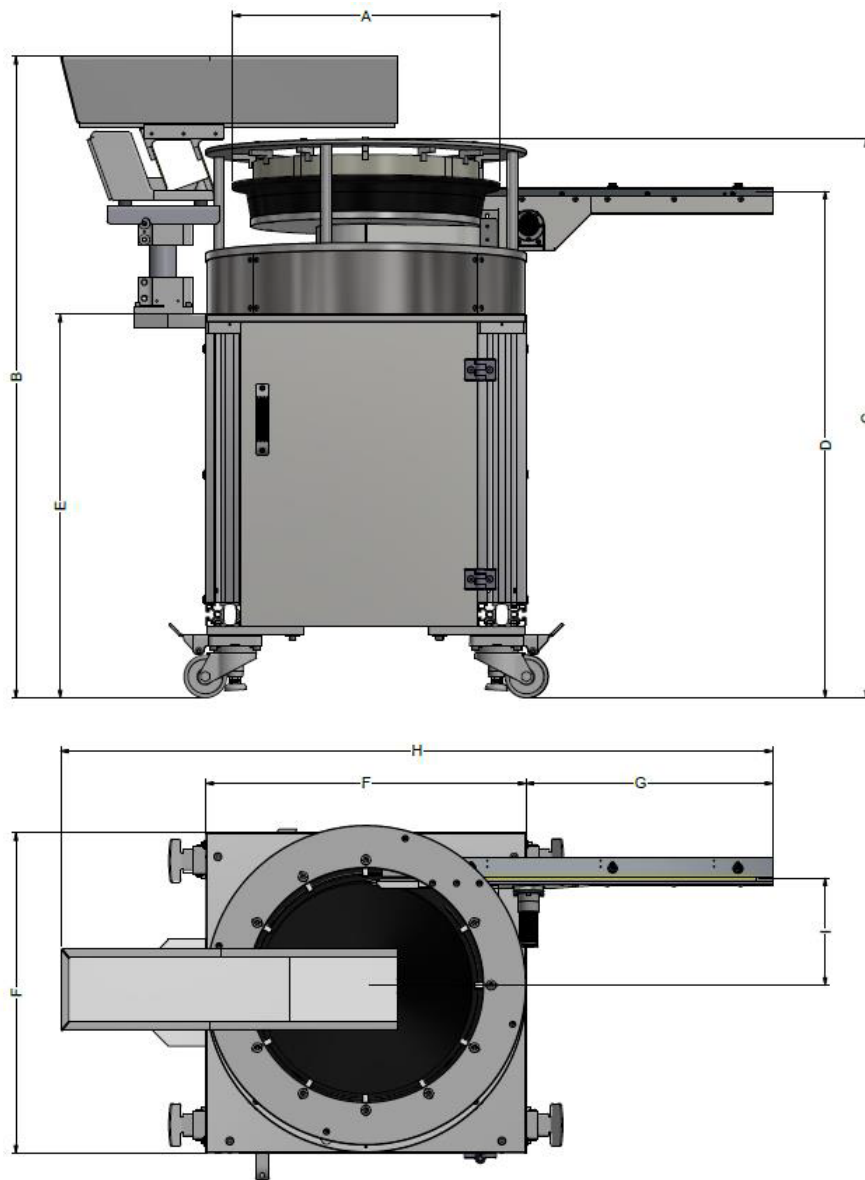

Article no. ID	Rotation direction	Dimensions (in mm)								
		A	B	C	D	E	F	G*	H	I
FCC-300-CW	CW	300	1'160	1'027	940	720	500	300	1'005	115
FCC-300-CCW	CCW									
FCC-500-CW	CW	500	1'202	1'047	950	720	600	400	1'335	200
FCC-500-CCW	CCW									
FCC-900-CW	CW	900	1'325	1'145	1020	720	1000	500	1'915	415
FCC-900-CCW	CCW									

CW: clockwise, CCW: counterclockwise
 * Belt length freely selectable from 200 to 1'000mm